



# 36-INCH REFRIGERATOR COLUMN PANEL-READY

DRR36980LAP | DRR36980RAP



## PRODUCT FEATURES

- Full height door with true flush cabinet integration without exposed venting grill
- SteelCool™ Stainless Steel Interior illuminated by 3DLighting™
- Push-To-Open™ Door Assist opens the door upon a slight push for a luxuriously convenient experience
- Internal Water Dispenser for easy access to clean, filtered water
- iQ RemoteView™ Cameras (Wi-Fi) enables users to check what's in your fridge from your phone

## TEMPERATURE RANGES

REFRIGERATOR	34°F (1°C) TO 44°F (7°C)
REFRIGERATOR - POWER COOL	34°F (1°C)
FRESHZONE™ DRAWER	37°F (3°C) / 33°F (-1°C) / 29°F (-1°C)

## DIMENSIONS & WEIGHT

APPLIANCE DIMENSIONS (W X H X D) (IN.)	35 3/4" X 83 3/8" X 25"
REQUIRED CUTOUT SIZE (W X H X D) (IN.)	36" X 84" X 25"
NET WEIGHT (LBS)	567

## GENERAL PROPERTIES

PANEL READY	YES
DOOR SWING	LAP-LEFT, RAP-RIGHT
PUSH-TO-OPEN™ DOOR ASSIST	YES
INTERNAL WATER DISPENSER	YES
IQ REMOTEVIEW™ CAMERA	YES (2 EA)
DEODORIZING FILTER	YES
LIGHTING	3DLIGHTING™
INTERIOR MATERIAL	STEELCOOL™ STAINLESS STEEL INTERIOR
FULL WIDTH SHELVES	4 EA
SHELF MATERIAL	TEMPERED GLASS SHELVES WITH METAL TRIM
FULL EXTENSION DRAWERS AT 90° DOOR OPENING ANGLE	YES
FRESHZONE™ DRAWER	CHEESE 37°F (3°C) / COLD DRINKS 33°F (1°C) / MEAT 29°F (-1°C)
CRISPER DRAWERS	2 EA
DOOR BINS	4 EA
DOOR OPEN ALARM	YES
SPECIAL MODES	SABBATH MODE

## CAPACITY

TOTAL UNIT GROSS CAPACITY (CU. FT.) - AHAM	21.6 CU. FT.
REFRIGERATOR GROSS CAPACITY (CU. FT.)	21.6 CU. FT.

## PERFORMANCE

DEDICATED EVAPORATOR & COMPRESSOR SYSTEM	YES
POWER COOL	YES
PRECISE COOLING	YES

## EFFICIENCY

ENERGY STAR® QUALIFIED	YES
ANNUAL ENERGY CONSUMPTION	290 KWH/YEAR

## TECHNICAL DETAILS

CURRENT (A)	15
VOLTS (V)	115
FREQUENCY (HZ)	60
POWER CORD LENGTH (IN.)	78 3/4"
PLUG TYPE	120 V, 3 PRONG

## WARRANTY

LIMITED, ENTIRE APPLIANCE, PARTS AND LABOUR ON ANY PART OF THE REFRIGERATOR	2 YEARS
LIMITED WARRANTY FOR SEALED REFRIGERATION SYSTEM; PARTS AND LABOUR	3 <sup>RD</sup> TO 6 <sup>TH</sup> YEAR
LIMITED WARRANTY FOR SEALED REFRIGERATION SYSTEM; PARTS ONLY	7 <sup>TH</sup> TO 12 <sup>TH</sup> YEAR
LIMITED WARRANTY FOR COMPRESSOR; PARTS ONLY	13 <sup>TH</sup> TO 15 <sup>TH</sup> YEAR

### APPLIANCE DIMENSIONS

A (WIDTH)	35 3/4" (908MM)
B (WITH PANEL)	25" (635MM)
B1 (WITHOUT PANEL)	23 13/16" (605MM)
C (HEIGHT)	83 3/8" (2118MM)
D	35 5/8" (905MM)
D1 (WITH PANEL)	36 7/8" (937MM)
D2 (WITH CONTEMPORARY HANDLE)	38 3/4" (985MM)
D3 (WITH PROFESSIONAL HANDLE)	39 3/8" (1,001MM)
E	62 7/8" (1597MM)
F	20 9/16" (496MM)
G	61 5/16" (1556MM)

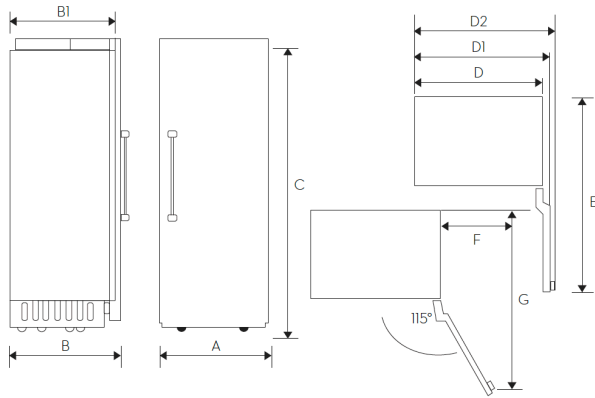

### INSTALLATION CUTOUT DIMENSIONS

A (WIDTH)	36" (914MM)
B (DEPTH)	25" (635MM)
C (HEIGHT)	84" (2134MM)
D	26" (660MM)
E	80" (2032MM)

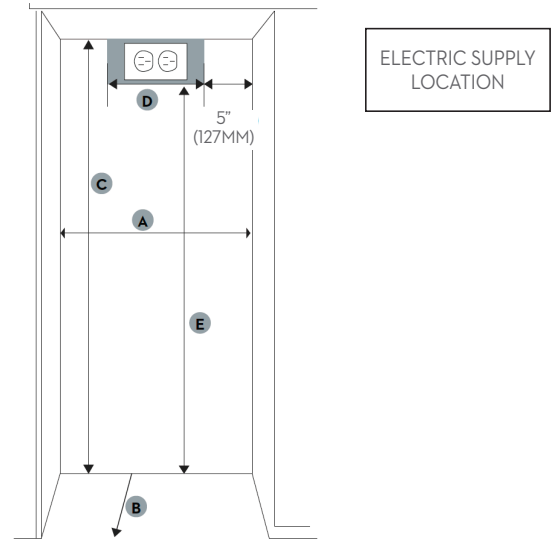

### CUSTOM PANEL DIMENSIONS

A-1 (WIDTH)	35 3/4" (908MM)
A-2 (HEIGHT)	79 7/8" (2029MM)
A-3 (DEPTH)	3/4" (19MM)
MAX WEIGHT	66.0 LBS. (30 KG)

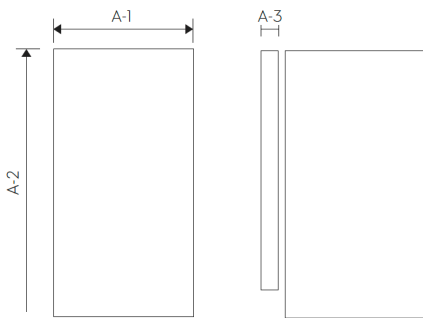

### WATER SUPPLY CONNECTION REQUIREMENTS

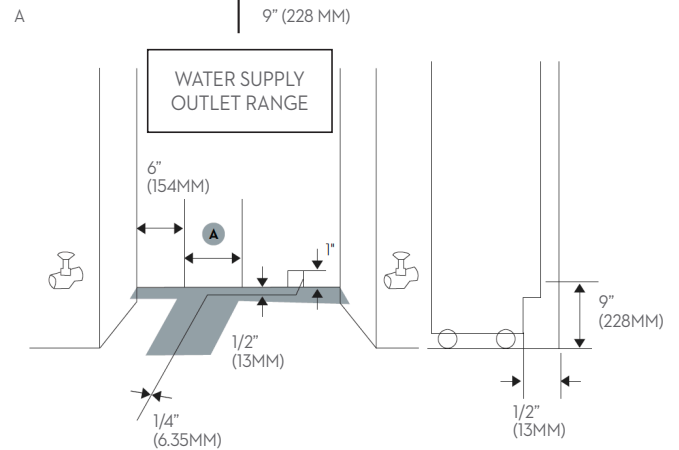

### ACCESSORIES

TRANSITIONAL SILVER STAINLESS STEEL - 36" PANEL KIT	RAC36ACLHSR (LEFT HINGE)	RAC36ACRHSR (RIGHT HINGE)
CONTEMPORARY GRAPHITE STAINLESS STEEL - 36" PANEL KIT	RAC36AMLHMS (LEFT HINGE)	RAC36AMRHMS (RIGHT HINGE)
CONTEMPORARY SILVER STAINLESS STEEL - 36" PANEL KIT	RAC36AMLHSR (LEFT HINGE)	RAC36AMRHSR (RIGHT HINGE)
PROFESSIONAL SILVER STAINLESS STEEL - 36" PANEL KIT	RAC36AHLHSR (LEFT HINGE)	RAC36AHRHSR (RIGHT HINGE)
CONTEMPORARY GRAPHITE STAINLESS STEEL - 36" KICK PLATE	RAC36TKBBMS	
CONTEMPORARY SILVER STAINLESS STEEL - 36" KICK PLATE	RAC36TKBBSR	
GRAPHITE STAINLESS STEEL - CONTEMPORARY HANDLE	RACOOMHAAMS	
SILVER STAINLESS STEEL - CONTEMPORARY HANDLE	RACOOMHAASR	
SILVER STAINLESS STEEL - PROFESSIONAL HANDLE	RACOOPHAASR	
PAIR INSTALLATION KIT	RACOOCPAAAA	
WATER FILTER	RAC00WFAAAA	
DEODORIZING FILTER	RAC00DFAAAA	