



INSTRUCTIONS D'ASSEMBLAGE
ASSEMBLY INSTRUCTIONS

MONARCH
SPECIALTIES INC.

I 2125

TABLE D'APPOINT -
48" L / TAUPE FONCE / CONSOLE D'ENTRE NOIR

ACCENT TABLE -
48" L / DARK TAUPE / BLACK HALL CONSOLE







**POUR DE L'ASSISTANCE OU POUR COMMANDER
DES PIÈCES CONTACTEZ NOTRE DÉPARTEMENT
DE SERVICE À LA CLIENTÈLE.**

**FOR ASSISTANCE OR TO ORDER PARTS
CONTACT OUR CUSTOMER SERVICE DEPARTMENT**

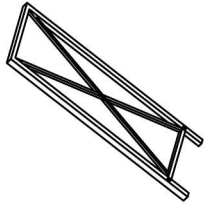
WWW.MONARCHSERVICE.COM

LISTE DES PIÈCES
PARTS LIST

PIÈCE / PART #	IMAGE	DESCRIPTION	QTY / QTÉ
1		METAL LEG PATTE EN METAL	2
2		CROSSBAR BARRE TRANSVERSALE	2
3		CROSSBAR BARRE TRANSVERSALE	2
4		TOP PANEL PANNEAU DE SURFACE	1
5		SHELF PANEL PANNEAU DE TABLETTE	1

LISTE DES PIÈCES DE MONTAGE
HARDWARE LIST

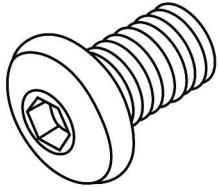
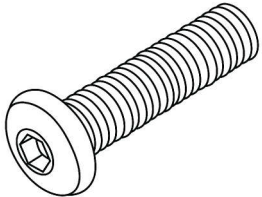
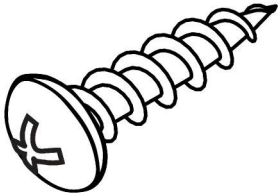
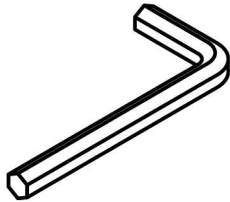
PIÈCE / PART #	IMAGE	DESCRIPTION	QTY / QTÉ
A		ASSEMBLING BOLT - Ø1/4" X 1/2" BOULON D'ASSEMBLAGE - Ø1/4" X 1/2"	8
B		ASSEMBLING BOLT - Ø1/4" X 1 5/8" BOULON D'ASSEMBLAGE - Ø1/4" X 1 5/8"	4
C		ASSEMBLING SCREW - 1/2" VIS D'ASSEMBLAGE - 1/2"	12
D		HEX KEY CLÉ HEXAGONALE	1

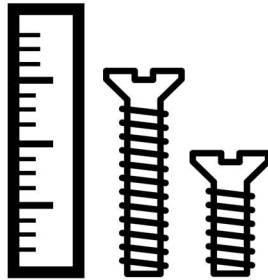

OUTIL DE VÉRIFICATION DE DIMENSIONS DES PIÈCES
HARDWARE DIMENSIONS VERIFICATION TOOL

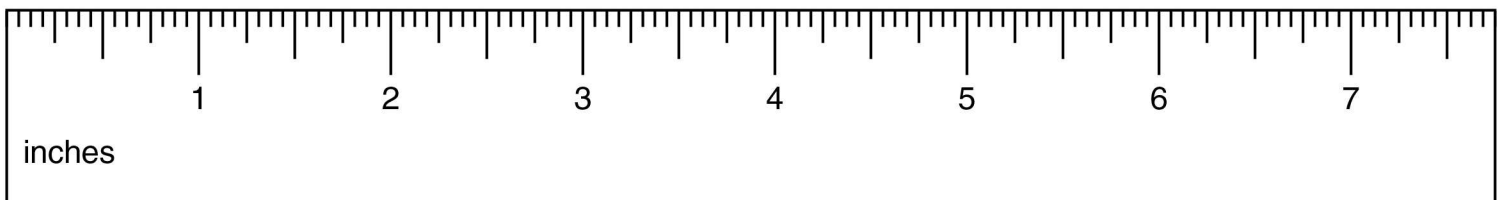

ÉTAPE / STEP 1

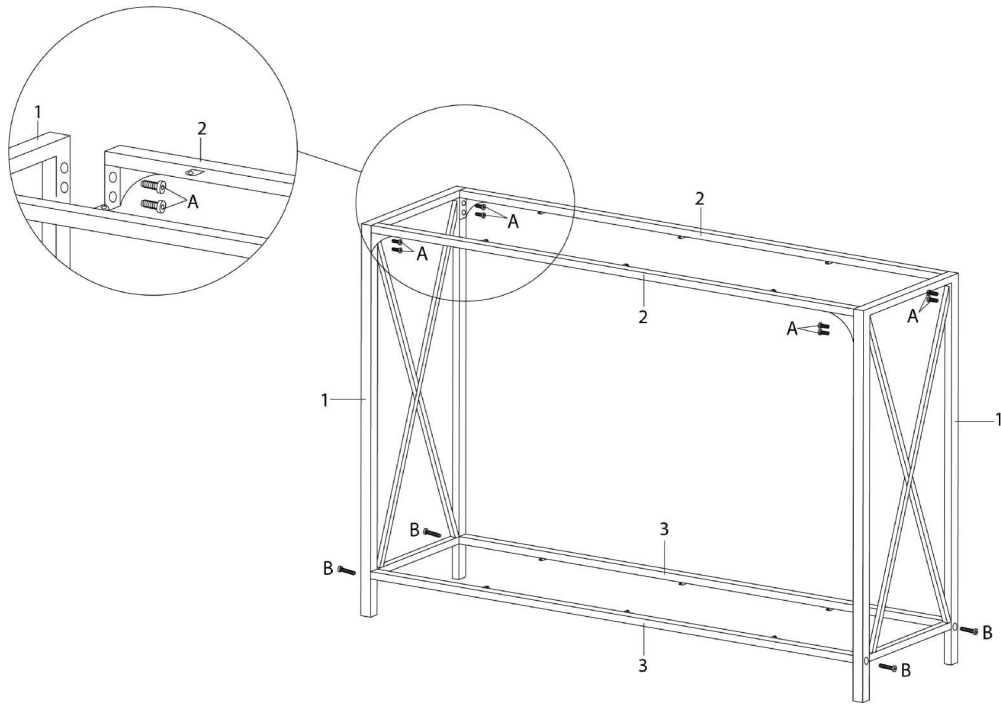

ÉTAPE / STEP 2

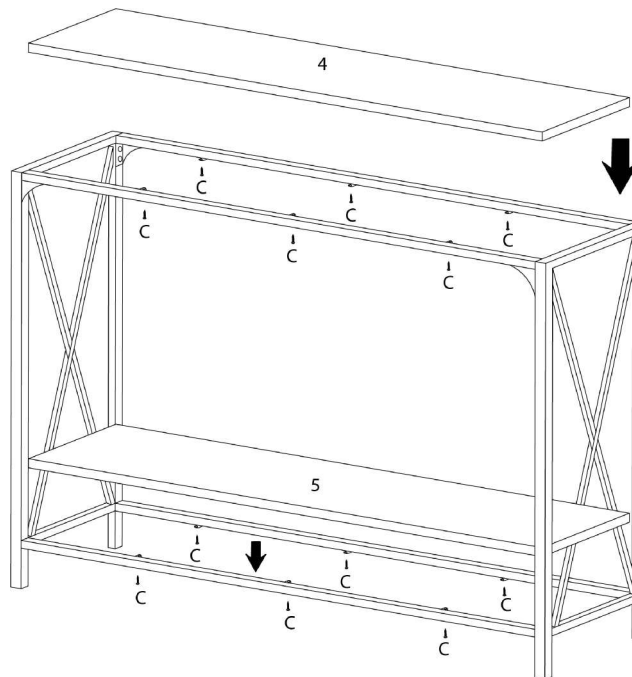

ÉTAPE / STEP 3

