

# DW24XV

## DISHWASHER 24" STAINLESS PANEL XV MODEL

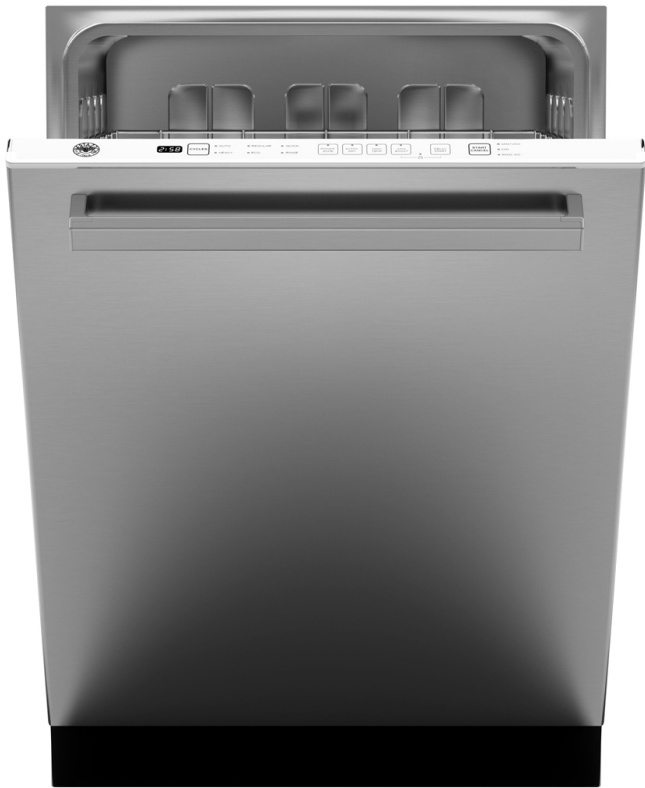

Extra-quiet performance 48 dB(A)

Dual pump system with food disposer and triple-stage filter ensure maximum removal of dirt residues from washing water

6 washing programs, 4 washing options and turbo drying ensure a customizable and always effective wash program

Sani-Boost option elevates washing temperature to 158F for perfect and sanitized cleaning

Energy Star compliant

Choose Professional, Master or Heritage Series handle kit to match your other Bertazzoni kitchen appliances

### PRODUCT FEATURES

<b>Style</b>	Stainless steel panel installed
<b>Interior finish</b>	Stainless steel tub
<b>User interface</b>	Concealed electronic touch interface
<b>Sound insulation</b>	48 db(A)
<b>Racks</b>	2 with height-adjustable middle rack
<b>Place settings</b>	14
<b>Wash cycles</b>	6 – Normal, Heavy, Auto, Quick, Rinse, ECO
<b>Wash options</b>	4 – Extra Dry, Sani Boost, Hi Temp, Delay Start
<b>Drying system</b>	Turbo drying
<b>Filter</b>	Triple-stage filter
<b>Food disposer</b>	Yes
<b>Sprayer arms</b>	3
<b>Lighting</b>	No

### TECHNICAL SPECIFICATIONS

<b>Voltage, Frequency, Amps</b>	120V 60Hz - 8.5 Amps 975W
<b>EnergyStar</b>	Yes 249 kWh/yr
<b>Power connection</b>	Direct wiring, no cord
<b>Water connection</b>	Min. 3/8" copper pipe with accessible shut-off valve
<b>Certification</b>	CSA
<b>Warranty</b>	2 years parts & labor

### ACCESSORIES

<b>PROHK24DW</b>	Handle kit 24" dishwasher XV/XT PROFESSIONAL SERIES
<b>PROHK24DWPI</b>	Handle kit 24" dishwasher XV/XT new range style PROFESSIONAL SERIES
<b>MASHK24DW</b>	Handle kit 24" dishwasher XV/XT MASTER SERIES
<b>MASHK24DWPI</b>	Handle kit 24" dishwasher XV/XT new range style MASTER SERIES
<b>HERHK24DW</b>	Handle kit 24" dishwasher XV/XT HERITAGE SERIES



DW24XV+PROHK24DW



DW24XV+MASHK24DW



DW24XV+HERHK24DW

# DW24XV

DISHWASHER 24" STAINLESS PANEL

XV MODEL



## SIDE

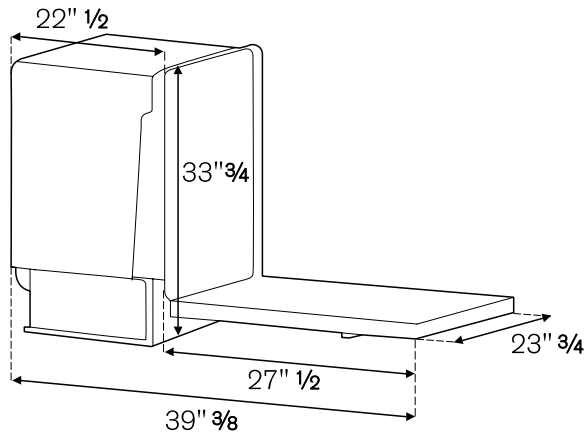

## FRONT

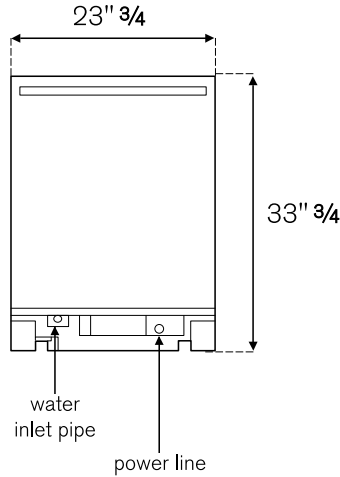

## BACK

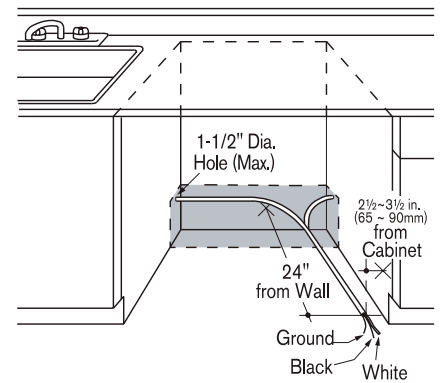
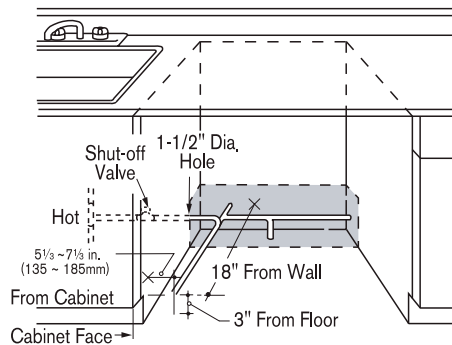
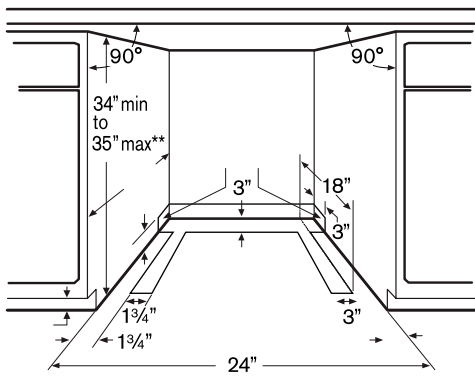
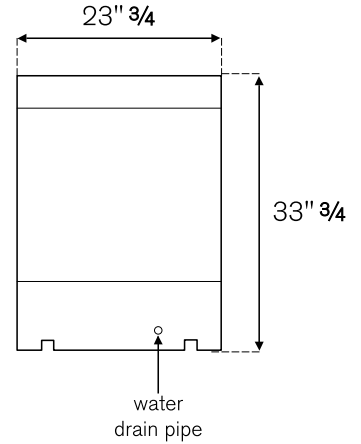

### WATER LINES:

Install water lines on either side, rear, or floor of shaded area. Line may pass through same hole as electrical cable and drain hose. If power cord with plug is used, water line **MUST NOT** pass through power cord hole.

### ELECTRICAL LINES

Install electrical line entry on either side, rear, or floor of shaded area. Must be connected to individual properly grounded circuit (with 15 – 20 A circuit breaker). Line must have 2 wires with a ground

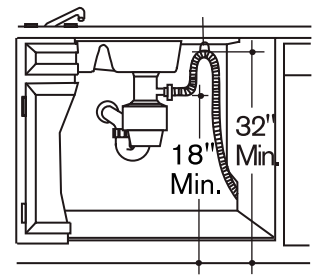
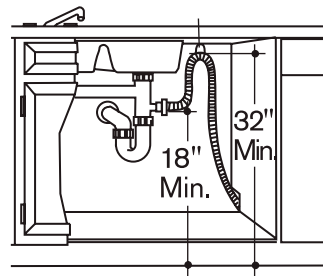
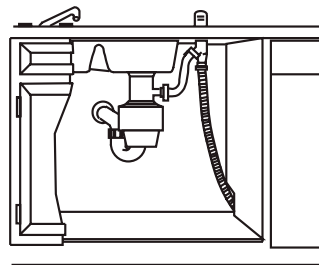
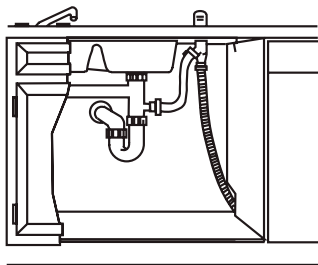

### DRAIN REQUIREMENTS:

Follow local codes & ordinances. Drain hose cannot exceed 10' distance to drain line.

### AIR GAP / HIGH DRAIN LOOP:

Install a waste line with an air gap (not supplied) or high drain loop to prevent backflow. High drain loop must be min 32" above floor. Air gap must be used if waste tee or disposer connection is less than 18" above floor.